

Electrical drawing

IS-033 400V-480V

Page title: Front Page

Project title: Baader IS-033 400V-480V

Project no.: EL.IS-033.400V.R11

Filename: Baader IS-033 400V R11

Last correction: 5.1.2015

Constructor Guðbrandur

Designer Guðbrandur

Drawing Jón Valur Valsson

Page 1

Number of pages: 9



Baader IS-033 400V-480V

	1
	2
Power wiring	3
Control circuit	4
Control circuit	5
Mechanical layout	6
Frequency converter programming	7
	8
	9
	10

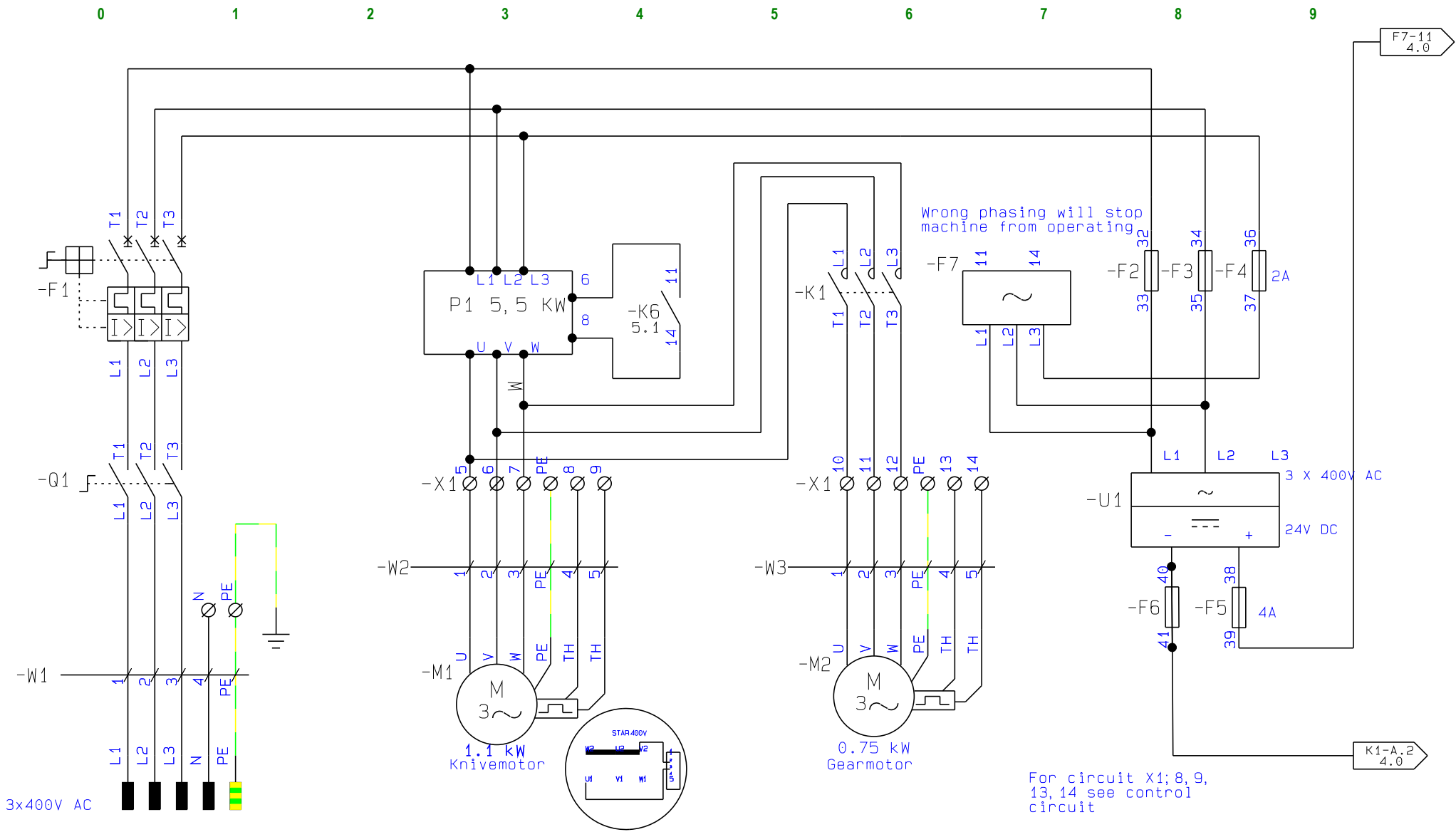

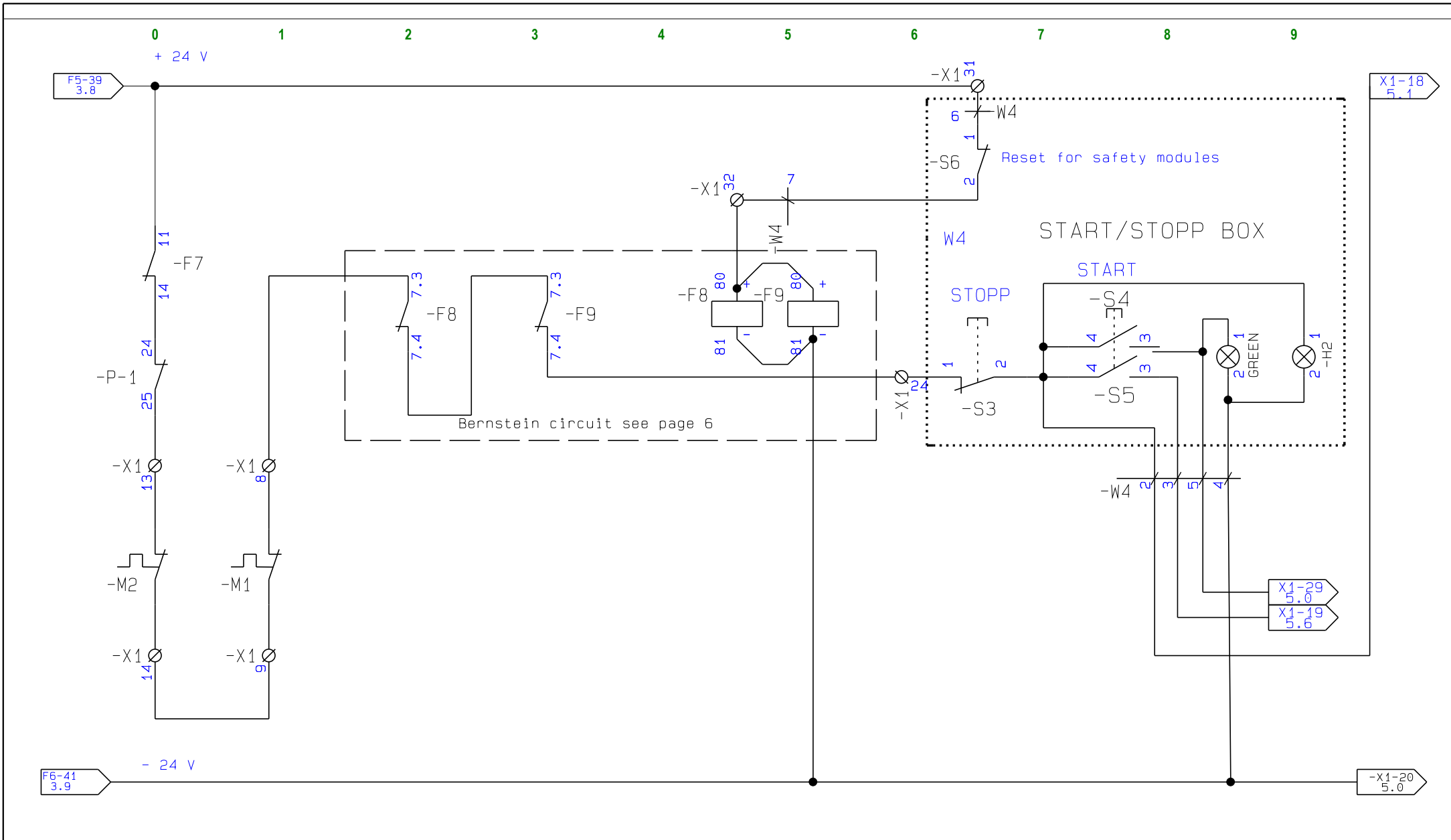

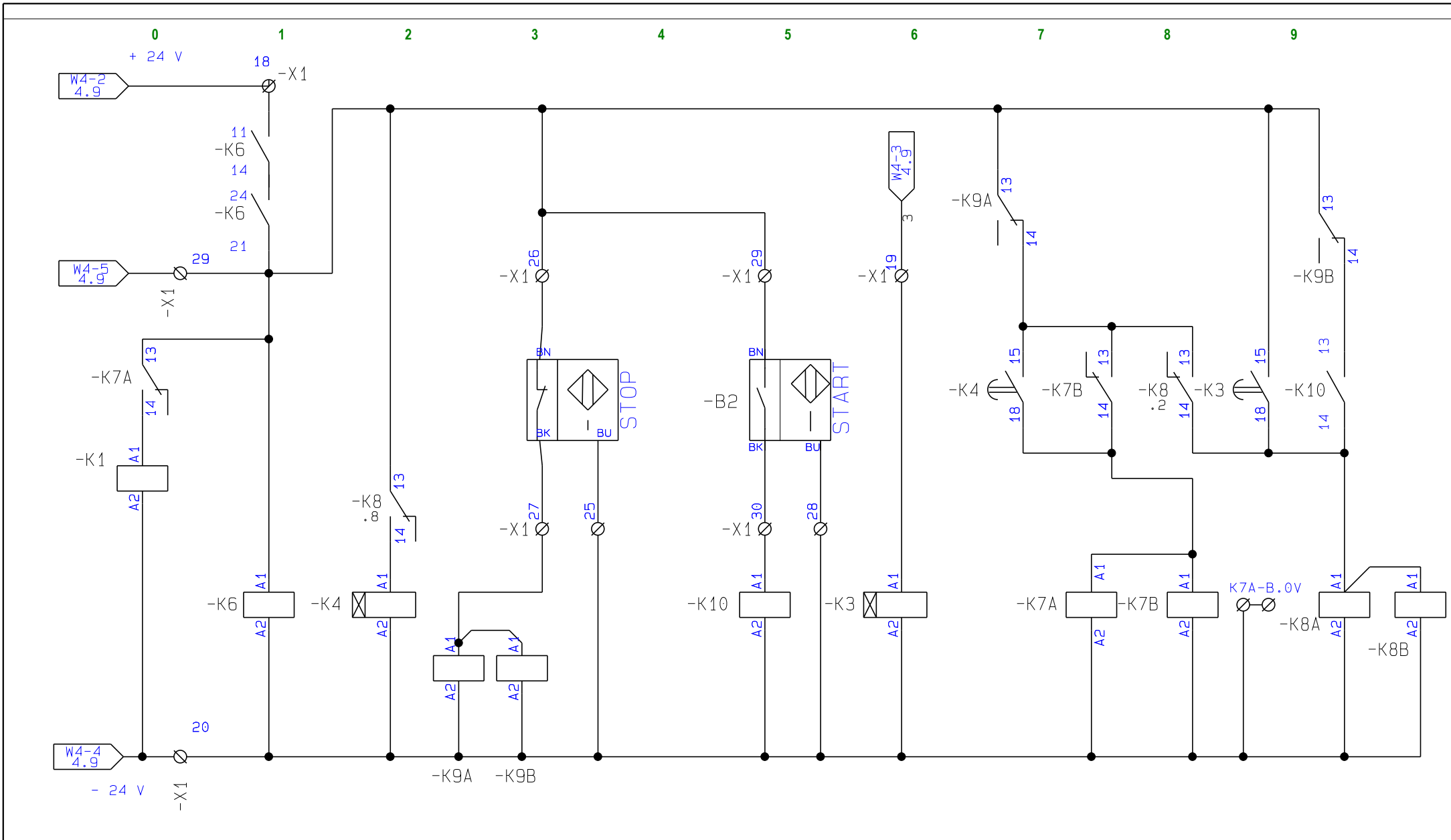

Circuit included in control circuit page 4

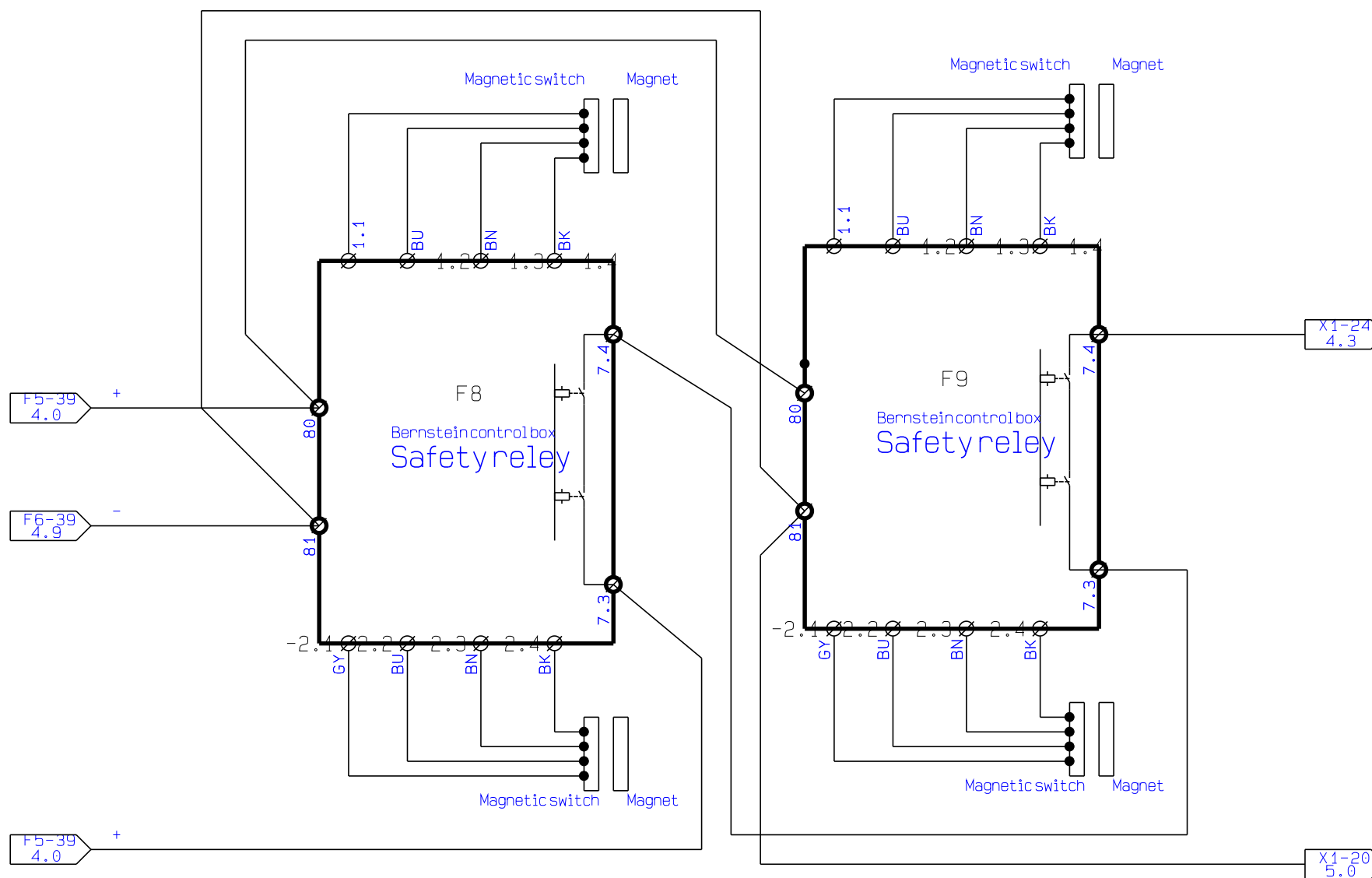

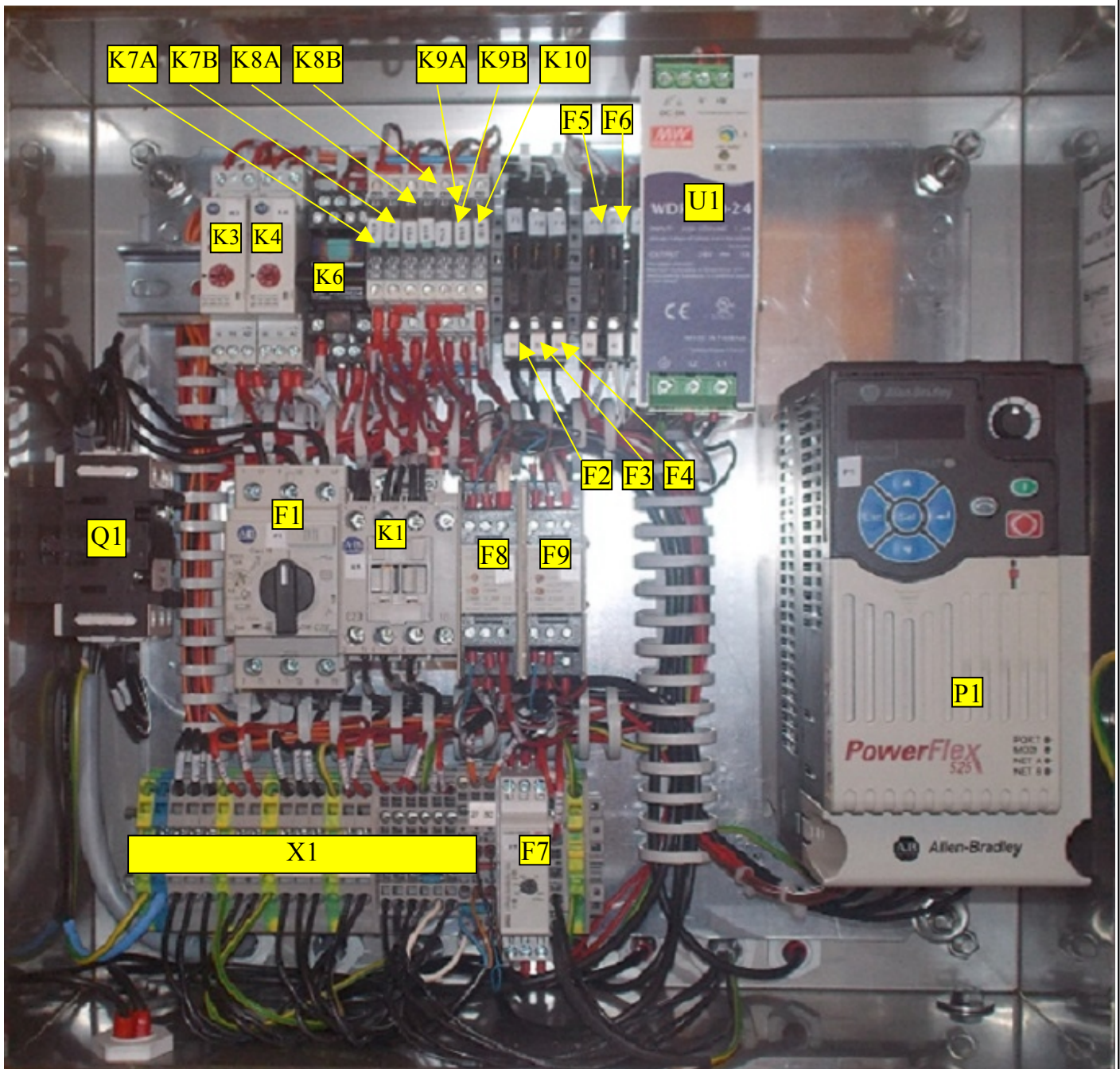

Name	Number	Position
Switch Disconnecter	07-6071685	Q1
Motor Switch	07-6064668	F1
Fuse Holder	07-3004100	F2-F6
Fuse	07-6115035	F2-F4
Fuse	07-6115065	F5-F6
Phase Monitor	07-DPA53CM48	F7
Safety Relay	79-6392702307	F8-F9
Power Supply	07-6065365	U1
Frequency Converter	07-6065140	P1
Contactor 24V DC	07-6061831	K1
Time Delay	07-6063040	K3-K4
Plug-in Relay Coupler	07-SALZS:PT5A5L24	K6
Optocoupler Relay	07-SA3TX70 04-3PB74	K7A-K10

Viewing and Editing Parameters

Step	Key(s)	Example Display
1. When power is applied, the last user-selected Basic Display Group parameter number is briefly displayed with flashing characters. The display then defaults to that parameter's current value. (Example shows the		
2. Press Esc to display the Basic Display Group parameter number shown on power-up. The parameter number will flash.		
3. Press Esc to enter the parameter group list. The parameter group letter will flash.		
4. Press the Up Arrow or Down Arrow to scroll through the group list (b,P,t,C,L,d,A,f and Gx).	or	
5. Press Enter or Sel to enter a group. The right digit of last viewed parameter in that group will flash.	or	
6. Press the Up Arrow or Down Arrow to scroll through the parameter list.	or	
7. Press enter to view the value of the parameter. Or Press Esc to return to the parameter list.		
8. Press Enter or Sel to enter Program Mode and edit the value. The right digit will flash and the word Program on the LCD display will light up.	or	
9. Press the Up Arrow or Down Arrow to change the parameter value.	or	
10. If desired, press Sel to move from digit to digit or bit to bit. The digit or bit that you can change will flash.		
11. Press Esc to cancel a change and exit Program Mode. Or, press Enter to save a change and exit Program Mode. The digit will stop flashing and the word Program on the LCD display will turn off.	or	
12. Press Esc to return to the parameter list. Continue to press Esc to back out of the programming menu. If pressing Esc does not change the display, then b001 [Output Freq] is displayed. Press Enter or Sel to enter the group list again.		

Programming Allen-Bradley Frequency Converter for IS-033 400V

Parameters for IS-033 400V

Code	Parameter	Value
P031	Motor nominal voltage	400V
P032	Motor nominal Frequency	50 Hz
P033	Current limit	13,8 A
P034	Motor nominal current	10,5 A
P036	Motor nominal speed	1440
P041	Acceleration time	3
P042	Deceleration time	0,5
P043	Min frequency	50 Hz
P044	Max frequency	50 Hz
P045	Stop function	0
P046	Start function	2
P047	Remote control place 1 frequency reference selection	2

For other parameters refer to factory settings